

PATENT NO:
US 8205396 B2

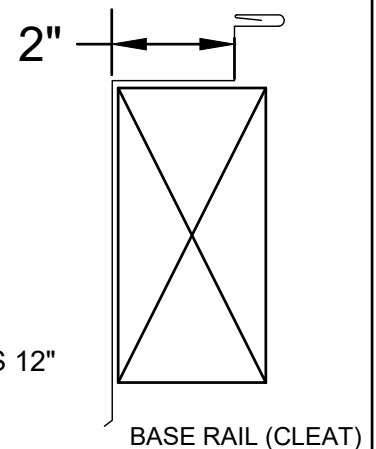
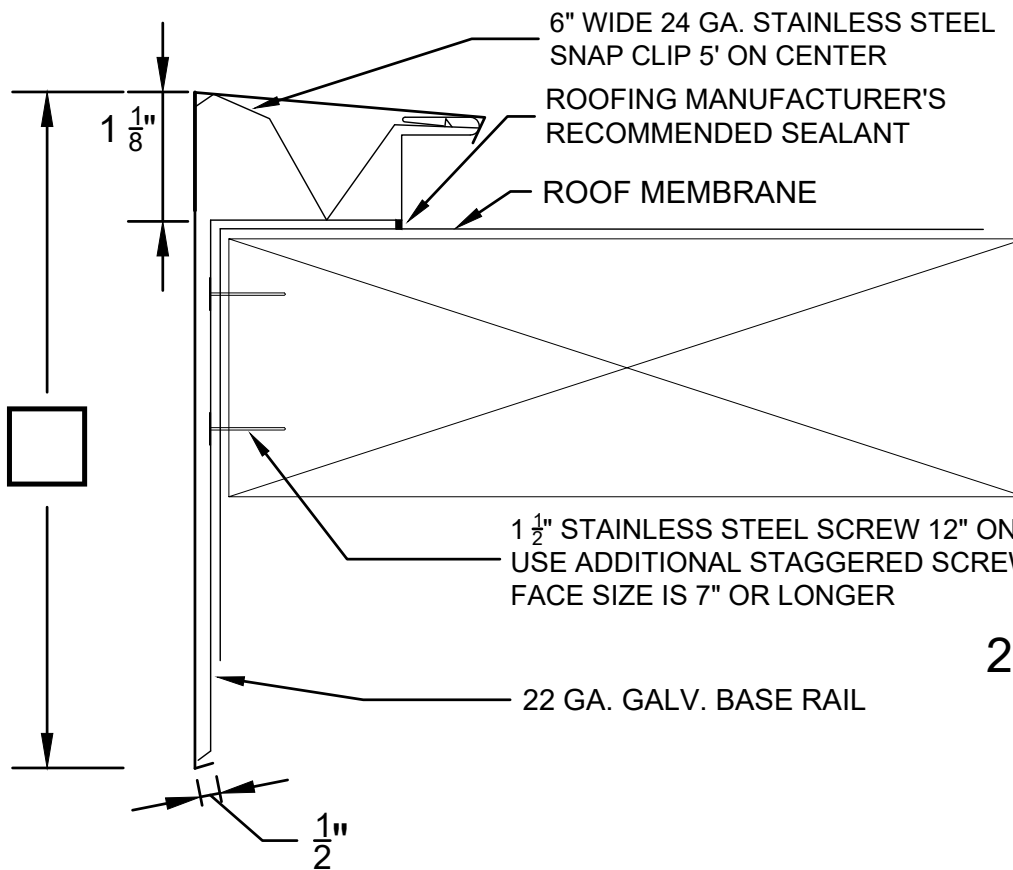

- MAX ANSI/SPRI ES1 TESTED FACE SIZE FOR 24GA, 22GA GALVANIZED IS 12"
- MAX ANSI/SPRI ES1 TESTED FACE SIZE FOR 040 ALUMINUM IS 16"
- MAX ANSI/SPRI ES1 TESTED FACE SIZE FOR 050, 063 ALUMINUM IS 16"

MATERIAL:

- 24 Ga. Galv. Steel
- .040" Aluminum
- .050" Aluminum
- .063" Aluminum

QUANTITY:

___ Lineal Feet (10' INCREMENTS)

Color: _____

Finish: _____

ACCESSORIES:

- ___ Outside Miters
- ___ Inside Miters
- ___ Left Endcaps
- ___ Right Endcaps

PROJECT NAME:

QUOTE:

ORDER: PO# _____

INSTALLER:

SIGNATURE

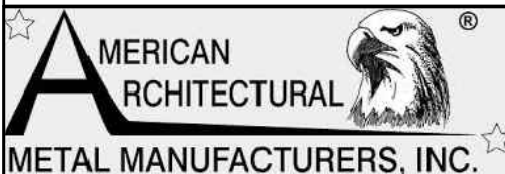

EAGLE PERIMETER EDGE SYSTEMS

ANSI/SPRI ES1 TRU SNAP[®] FASCIA