

PATENT NO:
US 8205396 B2

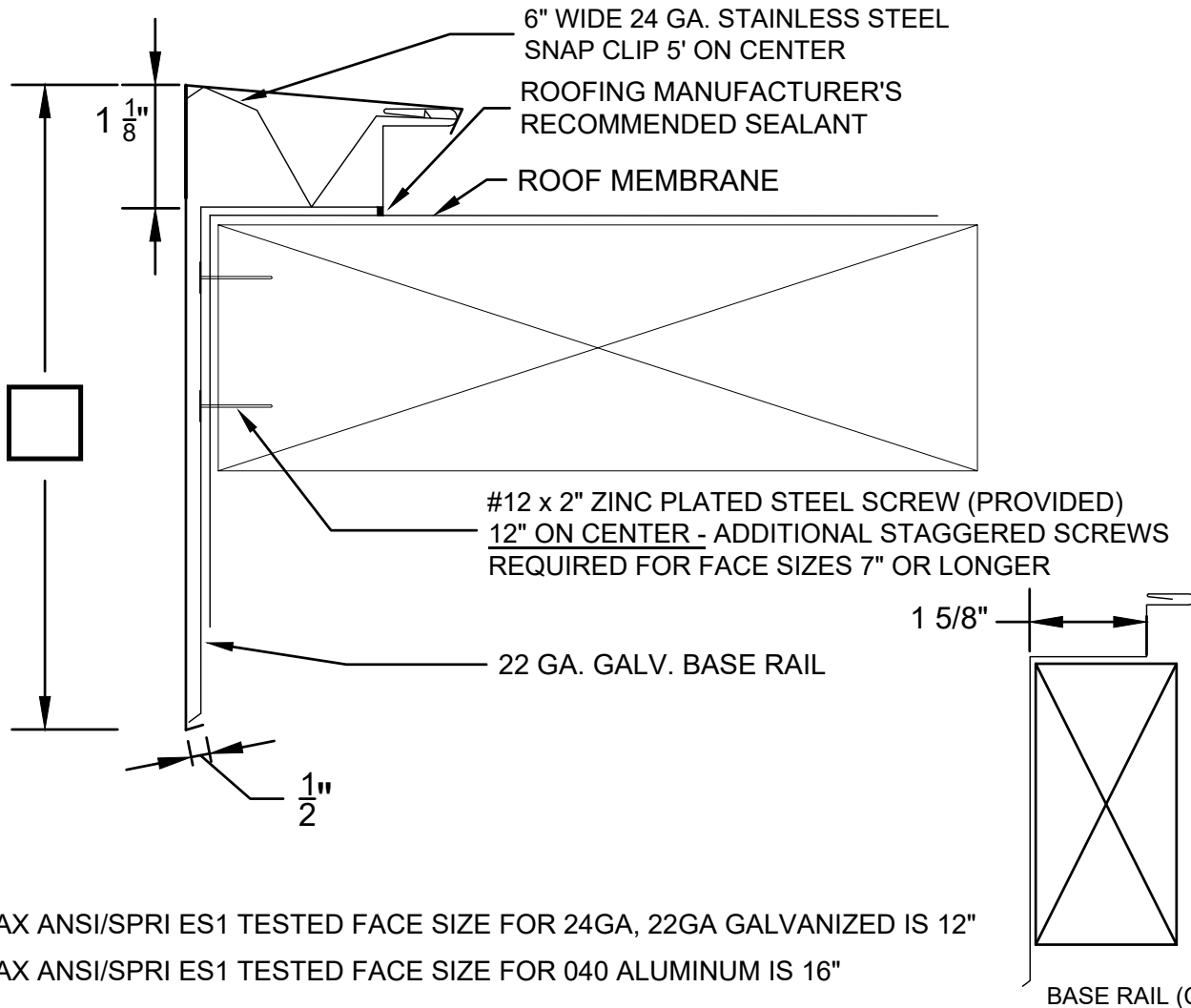

- MAX ANSI/SPRI ES1 TESTED FACE SIZE FOR 24GA, 22GA GALVANIZED IS 12"
- MAX ANSI/SPRI ES1 TESTED FACE SIZE FOR 040 ALUMINUM IS 16"
- MAX ANSI/SPRI ES1 TESTED FACE SIZE FOR 050, 063 ALUMINUM IS 16"

MATERIAL:	QUANTITY:	ACCESSORIES:
<input type="checkbox"/> 24 Ga. Galv. Steel	___ Lineal Feet (10' INCREMENTS)	___ Outside Miters ___ Inside Miters
<input type="checkbox"/> .040" Aluminum	Color: _____	___ Left Endcaps ___ Right Endcaps
<input type="checkbox"/> .050" Aluminum	Finish: _____	
<input type="checkbox"/> .063" Aluminum		

PROJECT NAME:	QUOTE: <input type="checkbox"/>
	ORDER: <input type="checkbox"/> PO# _____

INSTALLER:	SIGNATURE
------------	-----------

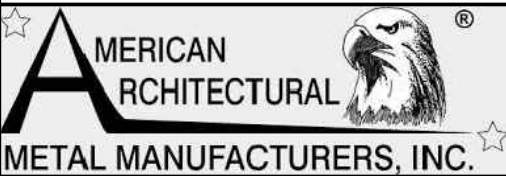

EAGLE PERIMETER EDGE SYSTEMS

ANSI/SPRI ES1 TRU SNAP[®] FASCIA